

Scheme 330

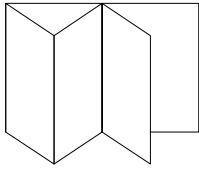

Scheme 321

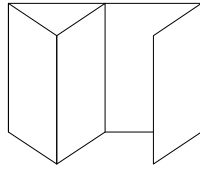

Scheme 431

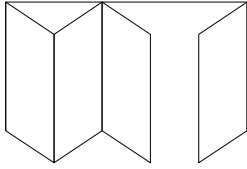

Scheme 541

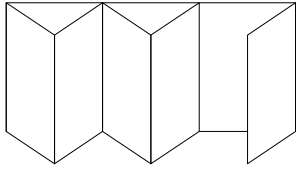

Scheme 550

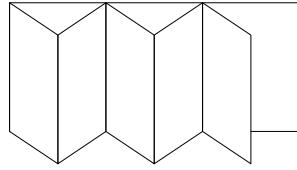

Scheme 532

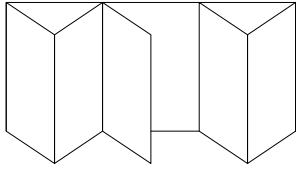

Scheme 651

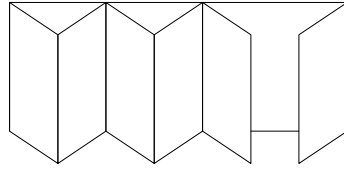

Scheme 633

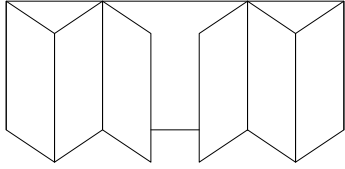

Scheme 761

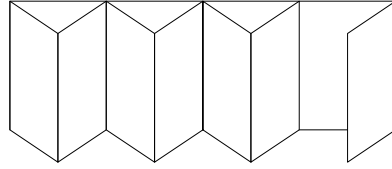

Scheme 770

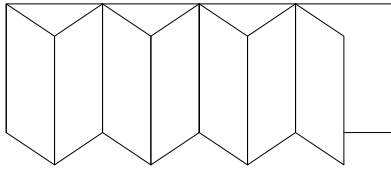

Scheme 743

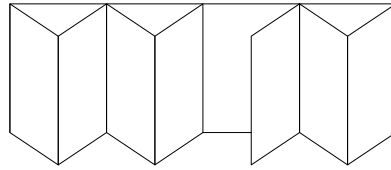

Scheme 871

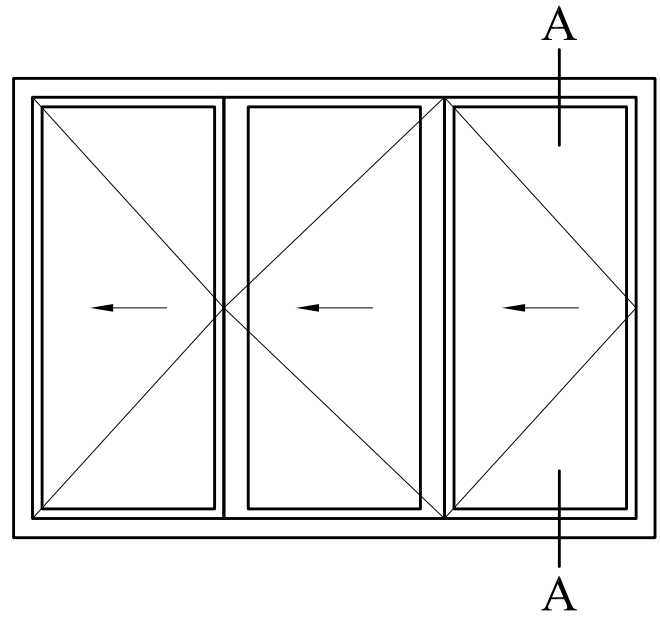
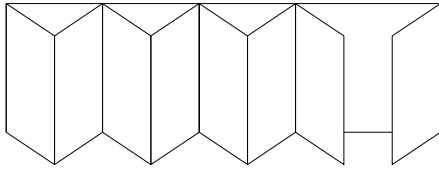

A - A

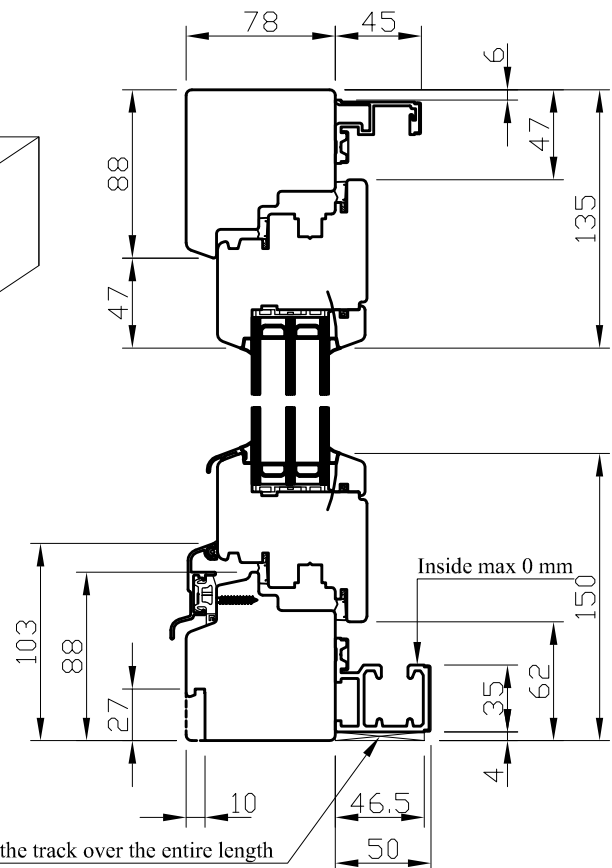

On the bottom underlay the track over the entire length

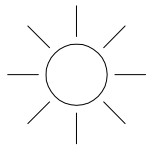

Scheme 330

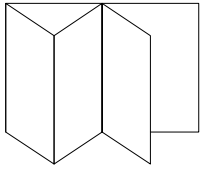

Scheme 321

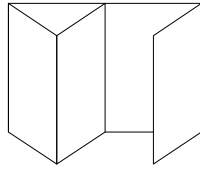

Scheme 431

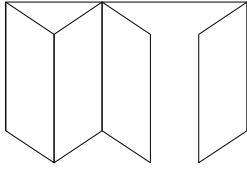

Scheme 541

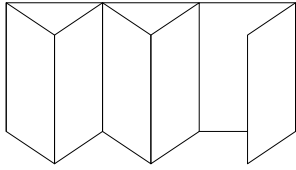

Scheme 550

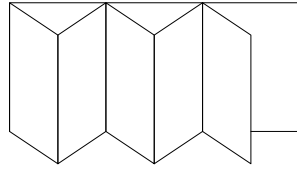

Scheme 532

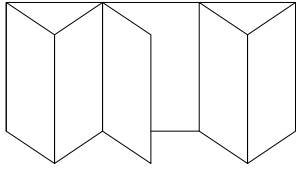

Scheme 651

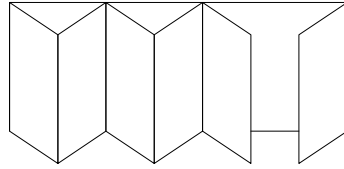

Scheme 633

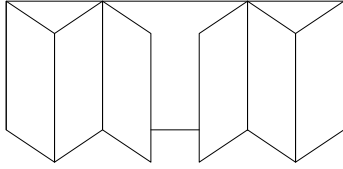

Scheme 761

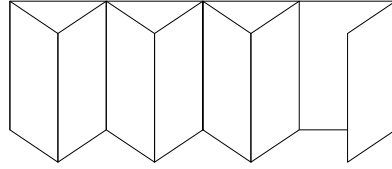

Scheme 770

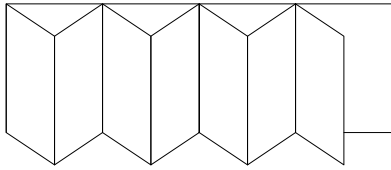

Scheme 743

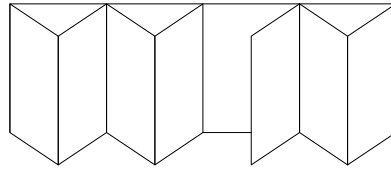

Scheme 871

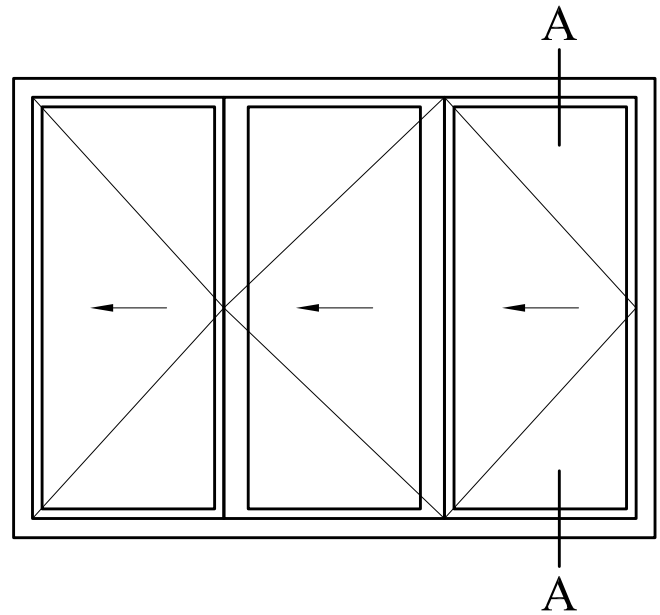
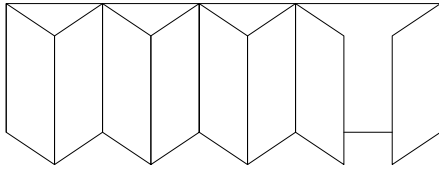

A - A

